

LINE-FOLLOWING ROBOT WITH PROTECTIVE FEATURES

Er. Faruk Bin Poyen, Er. Soumya Roy, Dr. Apurba Ghosh Deep Mukherjee
Dept. of Applied Electronics and Instrumentation Engineering
University Institute of Technology
The University Of Burdwan
Burdwan, India
School of Electronics
KIIT University, Bhubaneshwar

Abstract: Line follower Robot is not something that is new in the field of robotics but with some Add On features it can really some a little more handy and efficacy of the set up can be multiplied by many folds. Line Follower Robot is a mobile machine that can detect and trace the available white path which is drawn on the blackened surface. Robot should read for identifying its position in some time by sensing via infrared sensors. If we can provide this line following robot with some security features like smoke sensing capabilities, anti-breaching facilities, over heating sensors and fire alarms, the system will be highly beneficiary to the society. We have tried to put here a prototype model of the design which has run quite according to our expectations. Moving from here, the next phase is to implement the system in a real life scenario.

Keywords: Line follower robot, Touch Sensor, Smoke detector, fire alarms.

I.INTRODUCTION

Line-following robots with pick-and placement capabilities are commonly used in manufacturing plants. These move on a specified path to pick the components from specified locations and place them on to some desired locations. Basically, a line-following robot is a self-operating robot that detects and follows a line drawn on a floor. From the industrial point of view, line following robot has been implemented in semi to fully autonomous plants. In this environment, these robots function as materials carrier to deliver products from one manufacturing point to another where rail, conveyor and gantry solutions are not possible. Security systems have gained a high level of importance since occupational hazard is on the rise. There are numerous reasons for which we have tried our best to implement security system in the Automated Line Follower Robot. The major reason of using security system is in case of an emergency situation. Basically, the system includes alarm that will trigger a warning when there is something dangerous or unwanted like fire, intruders, or even theft occurs.



Fig. 1: A model of the Line Follower Robot.

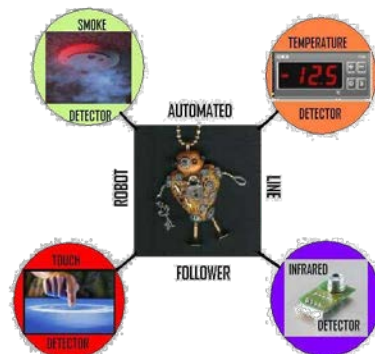

Fig. 2: The Big Picture.

II OUTLINE OF THE ROBOT

2.1. *Design:* The robot should be streamlined in shape in order to increase its speed and momentum. Our main motive is that the robot should possess the capability of moving freely in all directions i.e. it can take a 360° rotation about its horizontal axis if necessary. In case of four wheelers the sustenance of the stability is difficult at the turning points of the trailer. Therefore, in order to keep with the high stability we are using two wheels along with a free-wheel which is placed at the centre of gravity of the chassis of the car. The free-wheel helps in smooth rotation of the robot at the turning points of the track. When one wheel moves in clockwise direction and other moves in anticlockwise direction when there is a possibility of sharp turns ahead. It also helps in reduction of friction due to smaller contact surface area with the ground as compared to the two wheels which have a larger contact area with the ground and hence results in greater friction. Moreover, the time taken by a combination of two wheels along with a free-wheel to turn around is lesser comparing to the time taken by a four-wheeler to do so. We supposedly feel that the rear side of the robot should not be heavier to the front side of the robot and The vice-versa. It will lead to imbalance conditions and hence will incur problem in following the track. Similarly if the chassis is heavier as compared to the combination of the wheels and free-wheel, then also it will lead to imbalance of the centre of mass.

2.2. *Selection of Sensors:* Many types of sensor like Infrared LEDs, Photodiodes, Photo Transistors, Opto-couplers, LDRs and other optoelectronic sensors can be used to detect the white track on the black surface.

But here we are using Infrared LEDs to detect the path. This sensor generally consist of two LEDs, one acts as transmitter and the other one acts as receiver. The main reason of selecting IR LEDs over other Opto-electronic sensors is due to the colour combination of the path which is black and white. Since, black path acts as a perfectly black body surface which absorbs the IR radiation emitted by IR transmitter so the IR receiver cannot receive the radiation from the transmitter but in case of white path, the opposite phenomenon takes place i.e. the IR receiver receives the radiation from the IR transmitter and hence it detects the path. As the LDR is dependent on the intensity of light and due to its nonlinear characteristic it is less efficient as compared to IR LEDs. Also if huge current passes through the LDR then it gets heated up and burns out. Moreover, with respect to other Optoelectronic sensor the lifespan of the IR LED is much higher and is cost efficient and reliable.

2.3 *Placement of Sensors:* In order to achieve successful navigation, the number of sensors used and location on which sensors are placed play an important role. Inadequate number of sensors would result in a reduction of sensor resolution and could even prevent the robot from following a line. Based upon the test pitch requirement, it was deduced that the sensor array would require more than 2 sensors. To enable efficient line following capabilities, a minimum of 2 sensors is required (refer to figure 1(c)). However, 2 sensors are not enough to distinguish a single line from a junction; hence various possible arrangements were looked into. This is shown in figure 1.

Referring to figure 1(a) and 1(b), the matrix and line configuration would be possible solutions to achieve junction detection. However, looking into the matrix configuration and relating it back to the ALF movement on the test pitch, this configuration uses too many sensors. For example, there are 8 sensors located on top of the vertical line which is superfluous for line navigation purposes. In addition to that, there are also 4 sensors located in a vertical fashion on the extreme left and right of the sensor array which in this is supposed to function as junction detection. This also is considered to be too much for junction detection.

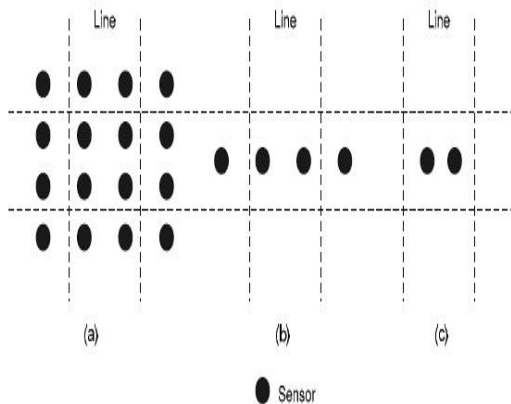

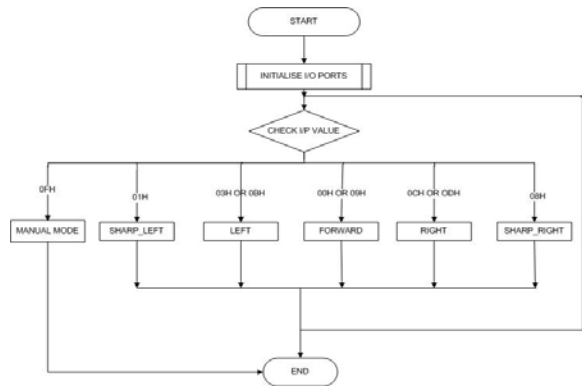

Motor Drive Logic
 Input (Sensor) To Output (Motor) Logic:
 Flowchart

E	I	I	E	I	I	L	L	R	R	M	M	M
N	N	N	N	N	N							
L	L	L	R	R	R							O
												V
												E

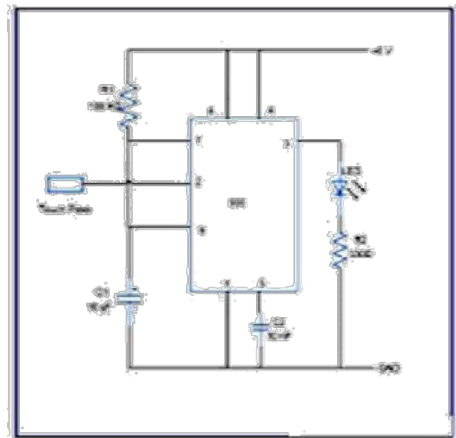
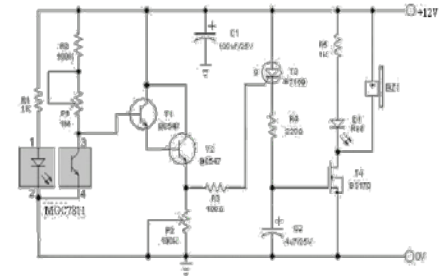
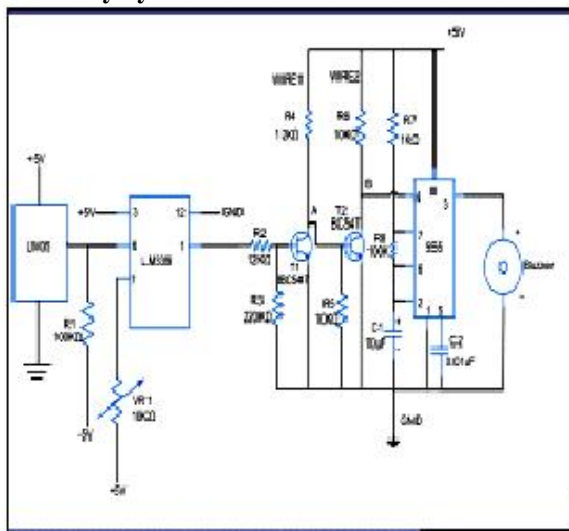

Fig. 3: Different types of sensor array (a) Matrix type sensor array, (b) Single line sensor array, (c) Basic two-sensor configuration

III MOTION CONTROL OF THE ROBOT

4. Security System:



V LIMITATIONS AND PRECAUTIONS

- a) Choice of line is made in the hardware abstraction and cannot be changed by software.
 - b) Calibration is difficult, and it is not easy to set a perfect value.
 - c) Lack of a four wheel drive, makes it not suitable for a rough terrain.
 - d) Use of IR even though solves a lot of problems pertaining to interference, makes it hard to debug a faulty sensor.
 - e) Lack of speed control makes the robot unstable at times.
 - f) The robot must be capable of following a line.
 - g) It should be capable of taking various degrees of turns
 - h) It must be prepared of a situation that it runs into a territory which has no line to follow. (Barren land syndrome)
 - i) The robot must also be capable of following a line even if it has breaks.
 - j) The robot must be insensitive to environmental factors such as lighting and noise.
- k) It must allow calibrator darkness threshold.
- l) Scalability must be a primary concern in the design.
- m) The color of the line must not be a factor as long as it is darker than the surroundings

VI. SCOPE OF BETTERMENT AND ADVANCEMENT

A number of improvements can be made done by increasing the number of sensors and changing the algorithm accordingly and we are working on them and trying to sort out things which will lead to the following.

- The movement will become smoother.
- It will also be able to detect the obstacles that come in its path.
- At sharp turn it will not face any problem.
- Even on thin track it will run smoothly.
- Use of differential steering with gradual change in wheel speeds.
- Using Hysteresis in sensor circuit using LM339
- Using ADC so that the exact position of the line can be interpolated
- General improvements like using a low dropout voltage regulator, lighter chassis.
- Software control of the line type (dark or light) to make automatic detection possible.
- “Obstacle detecting se physical obstacles and continue on the
- Distance sensing and position logging & transmission.

CONCLUSION

Coming to the concluding note, we can use our this experimental project to a varied number of applications viz. it effectively overcomes problems such syndrome”breaks,andtour guidesline museums and other similar applications. It can be used as an automated car or as an industrial vehicle and it can also be sent to those places where human reachableness is tough or tedious. There may be several other application domains and improvement sectors. We slowly are working on several other prospects of the project and look forward to some notable and worthy contribution towards the society with our endeavour.

REFERENCES

- [1] M C W Eddie: „A Phone Based Remote Controller For Home and Office Automation“. IEEE Transactions on Consumer Electronics, Volume 40, No. 1, February 1994. pages 2834.
- [2] Sin Min Tsai: „A Service Of Home Security System On Intelligent Network“. IEEE transactions on Consumer Electronics, Volume 44, No. 4, November 1998. pages 13601366.
- [3] David and P Hildenhagen: „Remote Control by Telephone“, Elector India, June 1997.
- [4] Yang Lili, Yang ShuangHua, Yao Fang, “Safety and security of remote monitoring and control of intelligent home environments”, Proceedings IEEE International Conference on Systems, Man and Cybernetics, 2007, p 11491153.
- [5] K. Vlachos, T. Orphanoudakis, Y. Papaefthiou, N. Nikolaou, D. Pnevmatikatos, G. Konstantoulakis, J.A. SanchezP. “Design and performance evaluation of a Programmable Packet Processing Engine (PPE) suitable for highspeed network processors units”, Microprocessors and Microsystems 31, 2007, p 188–199.
- [6] J.G. Vinson etc., “SecureWay an Affordable Home Security System”. Proceedings, the Institute of Electrical and Electronics Engineers 28th Annual 1994 International Carnahan Conference on Security Technology, IEEE, pages 144146,1994.
- [7] Luo Ren C., Hsu Te Y., Lin Tung Y., Su, Kuo L., ” The development of intelligent home security robot” Proceedings of the 2005 IEEE International Conference on Mechatronics, ICM '05, 2005, p 422427.
- [8] Wu, BingFei, Peng, HsinYuan; Chen, ChaoJung “A practical home security system via mobile phones”, WSEAS Transactions on Communications, v 5, 2006, p 10611066.
- [9] Fujiyama Hiroyuki, “Systemonachip with security modules for network home electric appliances” Fujitsu Scientific and Technical Journal, volume 42, no. 2, SystemonaChip, 2006, p 227233.
- [10] G. Aranguren, L. Nozal, A. Blazquez, and J. Arias, "Remote control of sensors and actuators by GSM", IEEE 2002 28th Annual Conference of the Industrial Electronics Society IECON 02, vol. 3 , 58 Nov. 2002, pp.2306 2310.